



New!!! CTP Vane Air Starters

CTP Vane Air Starter Motors -

Vane air starters are the most commonly used air starters throughout the world. The vane motor develops maximum horsepower at a much lower speed of 5,000 to 6,000 rpm, and only requires a small amount of lubrication for maximum life. The decreased speed of the vane motor improves bearing life, and delivers more torque per pound of weight than piston air motors.

Vane Air Starter Features

- All models sealed for use in air or gas applications
- Offset design for simple mounting
- Powerful motors
- Multiple offset gear ratios: B = 2.18:1; C = 2.53:1; C = 2.69:1; D = 3.44:1, D = 3.94:1; E = 3.46:1
- Backcap ports for injection lubricating

Vane Air Starter Versatility

- Inertia and pre-engaged starters available
- 4 inlet, 4 exhaust, and 16 drive housing orientations
- 90-150 psi (6.2-10.3 bars) operation
- Inline and offset designs
- Left- and right-hand rotation available

Vane Air Starter Motor

Part #	Engine Model/Application
7W9655	3304/B, 3306/B
1065521	3306
7C3374	3508/B, 3512/B, 3516B
7C3372	3508/B/C, 3512/B, 3516/B/C, C32
1055081	C11, C12, C13, C15, C18, 3406, 3408

Turbine Air Starters†

Part #	Engine Model/Application
1544576	G3606, G3608
2463274	C15, C18

† Please allow 2 to 3 weeks delivery time.

* Other part no. not included in the list are available. Please contact your sales representative if you have any questions. Part Numbers are used for reference purposes only

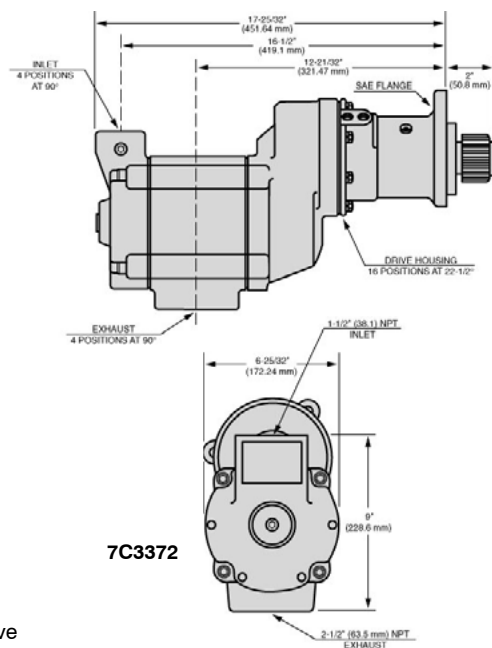

Other parts also available:

Part #	Description
6N7570	BOLT - SOCKET HEAD
4N4407	BUSHING - DRIVE HOUSING
7W0529	CLUTCH SPRING CUP - SLEEVE
5N8375	CUP - SPRING
5N8383	CYLINDER
6N7537	CYLINDER
4N4378	CYLINDER
4N4409	DEFLECTOR-1.25"
6N7538	DOWEL
7W0538	DRIVE HOUSING KIT
1244433	DRIVE PINION
1244434	DRIVE PINION
7W1650	DRIVE PINION
4N4384	GASKET - GEAR CASE
4N4376	GASKET - MOTOR HOUSING
2W6081	GEAR A
2W6082	HOUSING KIT - DRIVE
4N4383	HOUSING - MOTOR
5N8364	HOUSING - MOTOR
5N9574	JAW AS - CLUTCH
5N8390	KIT FOR 7C3372
6N7572	LOCKWASHER
1196284	LUBRICATOR GP
5N8363	MOTOR HOUSING COVER AS
5N8378	NUT - ROTOR CLAMP
4N4408	OILER - BUSHING
7W0519	PINION
2W6078	PINION - DRIVE
2W6079	PINION - DRIVE
4N4385	PINION - ROTOR
1055137	PISTON
5N8373	PISTON
4N4398	PISTON
6N7540	PLATE
4N4382	PLATE - FRONT END
5N8365	PLATE - FRONT END
4N4377	PLATE - REAR END

Part #	Description
5N8367	PLATE - REAR END
6N7536	RETAINER
6N7535	RETAINER -PINION
6V3971	RING RETAINER
4N4400	RING - SHAFT
5N8388	ROTOR
7W0514	ROTOR
7W4154	ROTOR
4N4381	ROTOR - ALUMINUM
7W0540	SEAL & VANE KIT
7C5105	SEAL KIT
4N4421	SHAFT - DRIVE
5N8384	SHAFT - DRIVE
6N7542	SHAFT - DRIVE
1078769	SILENCER
8N8488	SILENCER
1382544	SILENCER - 1.25"
5N8374	SLEEVE SPRING
6N7545	SPACER
4N4402	SPACER - SHAFT RING
5N8372	SPRING
5N8381	SPRING - CLUTCH
5N8380	SPRING - PINION
5N8389	SPRING - PINION
4N4403	SPRING - PISTON RING
2W6820	VALVE
4N3411	VALVE
4N4380	VANE KIT FOR 1055081
6N7533	VANE KIT FOR 7C3372
6N7547	WASHER
6N7571	WASHER
5N8425	WASHER - DRIVE PINION
5N8428	WASHER - DRIVE GEAR CUP

* Other part no. not included in the list are available. Please contact your sales representative if you have any questions.
Part Numbers are used for reference purposes only

ENGINEERED FOR SUPERIOR STARTING PERFORMANCE

CTP air starters are built to withstand the toughest environmental and working conditions — combining robust features and flexibility to deliver reliable, heavy-duty starting in a wide range of industrial, oil and gas, marine, power generation, rail, and mining applications.

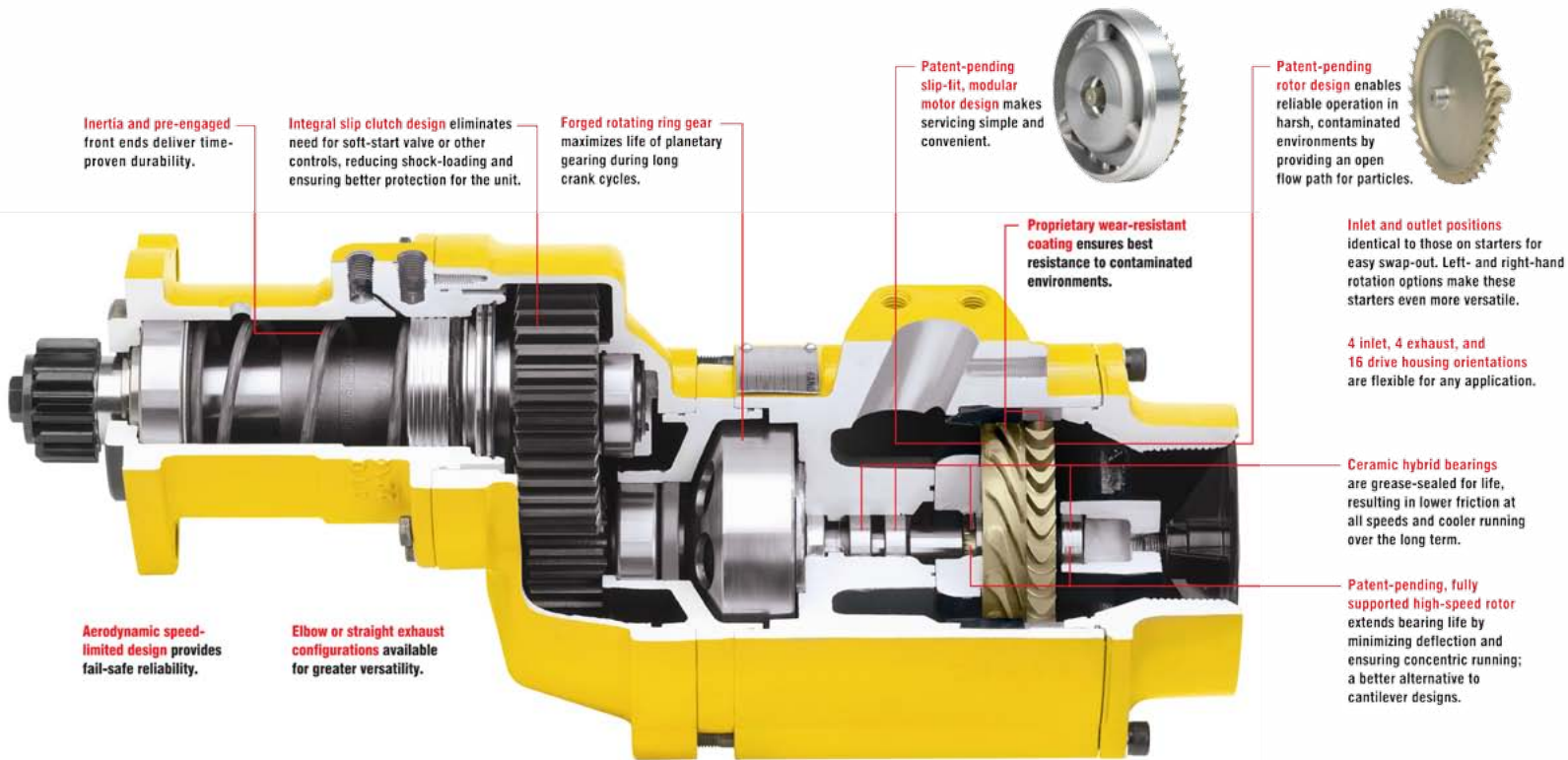

Brutal lab testing featuring steel shot in the starter's inlet line demonstrates rugged reliability

POWER AND
EFFICIENCY
DURABILITY
VERSATILITY

